

DC MOTOR SPEED CONTROLLER

MODEL: DCI250-24 *True Torque*™

Thank you for choosing Mtroniks to control your model.

Overview

For over 20 years Mtroniks have been at the forefront of electronic speed control design and manufacture for the hobby industry.

Our products are designed and manufactured entirely in house in the UK. The DCI range of controllers has been developed over the last 4 years. The extensive research and design program looked at every aspect of the problems associated with the speed control of large scale models.

We hope you will find the DCI range of controllers is refreshingly different in many ways; it's not designed down to price. We developed a strong core of electronics which during rigorous testing, has proven to be 'well on top of the job'

The use of a large and powerful computer core has allowed us to incorporate features and protection measures not usually found on these types of controllers. These particular controllers are aimed at large locomotives of 3 ½ " gauge and up. This is where we have tested extensively, actually in real applications.

True Torque™ Motor torque control system

Accurately measuring the current in the motor can be a difficult problem to solve in a model speed controller. For this reason, DC motor speed controllers normally control and if necessary limit the battery current.

However, at low motor speeds and high torque this can lead to severe motor overload because the current in the motor can be much higher than the average battery current.

Our new control system monitors every motor pulse and if necessary, adjusts the pulse to keep the motor current (Torque) to the maximum value set on the current control pre-set.

The usual problems of brush burning and motor overheating which occur because of magnetic saturation in overload are prevented.



Using your controller

General

Your new controller is simple to use and configure for use in your model, but there are a few important aspects which you should understand BEFORE you wire it into your model.

- 1) ALWAYS fit a fuse. Between 125 & 200Amp fuse in line with the positive (+ve) 24V supply feed from your battery.
- 2) Make sure that you use **DOUBLE** 10mm² wires, thin wires may heat up and melt, possibly causing short circuits or fires. The currents seen in ride on type locomotives can easily exceed 100Amps.
- 3) BE VERY SURE NOT to accidentally reverse connect to the battery, even a momentary touch on the wrong battery terminal can cause fatal damage to your controller. This will blow the 'tell tale' and your warranty does not cover damage due to reverse connection.
- 4) ENSURE that the dead-man device is fitted around the drivers wrist, failure to do so is a direct compromise on safety.
- 5) This unit is designed to be used by an adult and not to be left without adult supervision.

Installation notes

Install the controller power module into your model somewhere close to the battery, this helps to keep the battery wires as short as possible.

The power module gets warm during use, fastening the module to a metal chassis is ideal.

The power module only has 9 connections, 4 for the 24V battery supply, 4 for the motor/motors connections and one multi-way connector which allows connection to the controller handset.

NOTE: The small pin connectors are for factory use only. These are used for firmware/software updates. Depending on the model of the controller there may be fibre optic interface connections for master/slave operation. BE VERY CAREFUL TO NEVER interfere or damage these connections.

Using your model

The throttle control is disabled at switch on unless it is in the neutral band or is returned to neutral position after switch on.

Always apply power gently and progressively, rapid acceleration wears the motor brushes more quickly and places much greater stress on the drive train components.

The current control pre-set trimmer on your controller is **FRAGILE**, we strongly recommend that you use a jewellers screwdriver to CAREFULLY turn the control up or down.

If you know the manufacturers maximum rated current for your motor then this is the MAXIMUM current you should set on the control. If not, start low and work up, regularly checking the temperature of the motor.

As a rough guide there will come a point when further upward adjustment does not improve the power output. This is the maximum current/torque that the motor can handle. Adjust the control BACK a little and leave it there.

If you are travelling in one direction and switch to the opposite direction using the direction toggle switch, the controller will apply maximum brakes and stop. It will not apply power in the other direction until the throttle control is first returned to the neutral position for 2 seconds or longer.

The emergency stop button will, when pressed momentarily, apply maximum brakes and when close to stopping, the controller will short the motor to apply absolute maximum brakes. The power to the unit MUST be switched off then back on again to reset an emergency stop.

The 'dead man' jack plug is located on the front edge of the controller handset, when removed, full brakes are applied as in an emergency stop condition.

If your model does not respond to the handset please check the diagnostic light on the speed controller. It may be flashing in a sequence, see below.

- 1 Flash = Problem with the dead man switch – check it is secure
- 2 Flashes = Handset problem – Make sure it is connected correctly and not damaged
- 3 Flashes = Master/Slave optical coupling problem – check cable is not damaged and fitted ok

Features

- Fully regenerating, digital, high frequency operation
- Anti-lock brakes
- Patented motor current/Torque limiter system
- Master/Slave configuration – Fibre optic link
- Intelligent control bus – Failsafe & 'Dead man' safety plug
- Waterproof power module
- 24v DC operation /240Amps maximum
- Over temperature protection
- Ultra smooth power control
- Firmware/Software upgradeable
- 6.0mm studs for heavy duty power connections

Optional Accessories

Description	Part No.
○ Supply fuse and holder	DC250SF
○ 2m red/black 10.0mm ² cable w/connectors	DC250W2M
○ 1m red/black 10.0mm ² cable w/connectors	DC250W1M
○ Spare/Replacement handset	DCI Handset
○ Handset cable assembly	DCI Cont Cable
○ Fibre optic cable (3.0m)	DCI Fibre Cable(3m)
○ Fibre optic cable (10.0m)	DCI Fibre Cable (10m)
○ Relay board for auxiliary outputs	DC/AC RL424V

APPENDIX1

Master/Slave operation (Controller specific)

The DCI range of controllers come with the factory specified option of being able to link more than one controller via a fibre optic cable.

This allows 2 or more controllers to be operated together from one single handset. The maximum length of fibre optic cable which can be used is 20.0m, this denotes the maximum distance you can have between 2 controllers. Applications include 'topping and tailing' train configurations and also very high power, multi motor, locomotives.

When the second controller is set to slave, it is controlled, via the optical link, by the first 'master' controller which is controlled by the handset.

The fibre optic cable is the ideal way to connect the controllers, there is no electrical connection between the 2 controllers and no wires to damage or short out.

If the optical cable is broken, the slave controller will revert to neutral and freewheel until you can stop and repair/replace the cable.

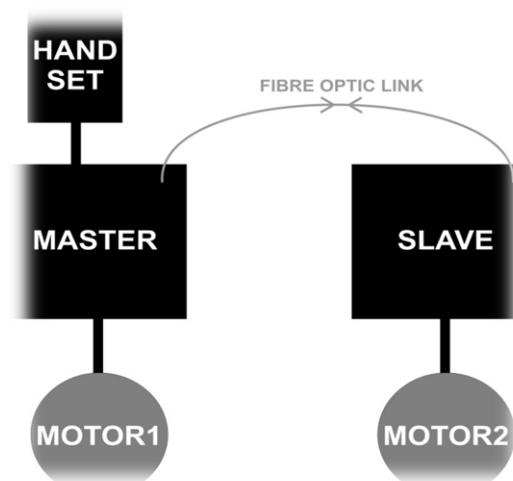

Auxiliary switched outputs

The DCI controller has up to 4 auxiliary switched outputs. These connections are controlled by the 4 switches on the handset.

The 4 connections on the controller are 'switched to ground' outputs. This means that they are designed to switch the coil of a relay.

The auxiliary relay board (DC/AC RL424V) allows you to wire the 4 auxiliary connections from the DCI250 to the inputs on the relay board allowing control of up to 4 auxiliary outputs, such as a horn or sound module.

Suggested wiring diagram

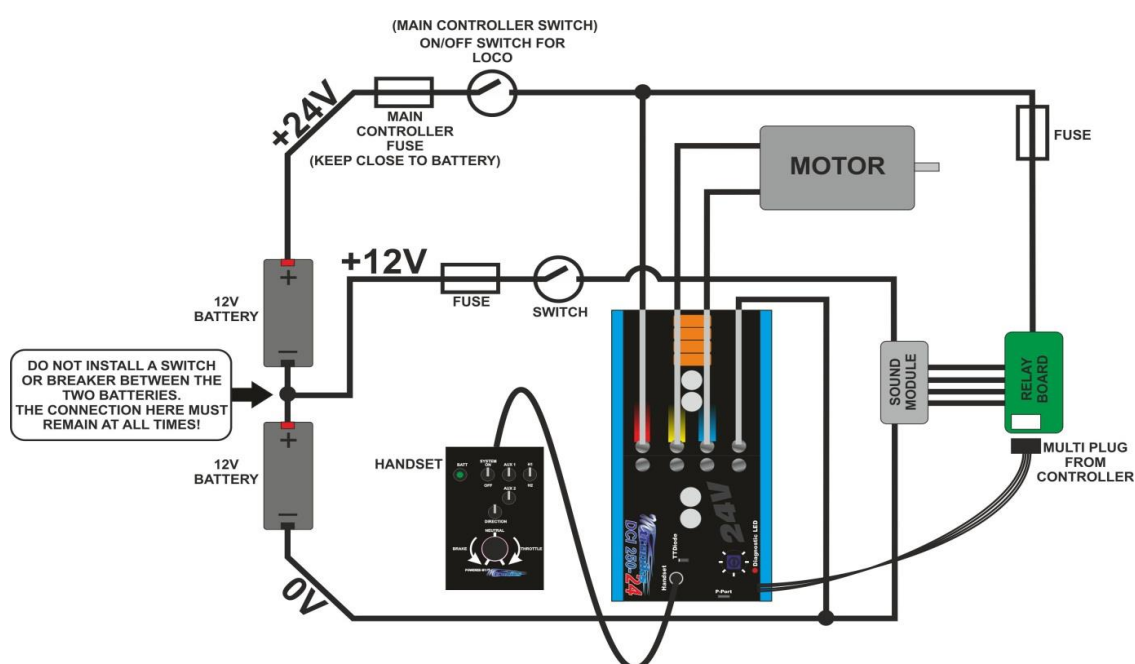

If running two motors, connect one motor to each of the motor terminal pairs. We also advise doubling up your power wires to the battery by connecting to both pairs of connectors.

General user notes

When installing an extension cable between the speed controller and the locomotive bulkhead it is very important to make sure that the bulkhead connection is electrically insulated from the locomotive chassis otherwise electrical noise in the chassis can be coupled into the handset control signals causing cut outs and failsafes. The best way to do this is to fit the metal socket at the bulkhead into an insulating mounting (this can be fibreglass or plastic) and then fasten the mounting to the bulkhead or buffer beam.

While you may be strongly tempted to construct your own extension lead we strongly recommend the use of our optional accessory as this is a high frequency digital control bus and the signals can easily be corrupted by a poor connection.